

# PRESSURE SETS WITH VESSEL



HYDROFRESH 24 SF



HYDROFRESH 24 CL



HYDROFRESH 60 CL

## PERFORMANCE

TIPO	POWER		FLOW RATE (1) l/min	SETTING (2) bar
	kW	HP		
<b>HYDROFRESH 24 SF</b>				
PKm 60 - 24 SF	0.37	0.50	32	1.4 ÷ 2.8
JSWm 1CX - 24 SF	0.37	0.50	45	1.2 ÷ 2.6
JSWm 1BX - 24 SF	0.50	0.70	50	1.4 ÷ 2.8
JSWm 1AX - 24 SF	0.60	0.85	50	1.8 ÷ 3.2
JSWm 10HX - 24 SF	0.75	1	50	2.0 ÷ 3.2
JSWm 12HX - 24 SF	0.90	1.25	50	2.5 ÷ 4.0
JSWm 15HX - 24 SF	1.1	1.5	50	3.0 ÷ 4.5
<b>HYDROFRESH 24 CL</b>				
PKm 60 - 24 CL	0.37	0.50	32	1.4 ÷ 2.8
PKm 65 - 24 CL	0.50	0.70	40	1.5 ÷ 3.0
CPm 620 - 24 CL	0.75	1	90	1.8 ÷ 3.2
CPm 650 - 24 CL	1.1	1.5	120	2.2 ÷ 3.5
JSWm 1BX - 24 CL	0.50	0.70	50	1.4 ÷ 2.8
JSWm 1AX - 24 CL	0.60	0.85	50	1.8 ÷ 3.2
JSWm 10HX - 24 CL	0.75	1	50	2.0 ÷ 3.2
JSWm 12HX - 24 CL	0.90	1.25	50	2.5 ÷ 4.0
JSWm 15HX - 24 CL	1.1	1.5	50	3.0 ÷ 4.5
JSWm 10MX - 24 CL	0.75	1	80	1.4 ÷ 2.8
JSWm 12MX - 24 CL	0.90	1.25	80	2.0 ÷ 3.5
JSWm 15MX - 24 CL	1.1	1.5	80	2.5 ÷ 4.0
JCRm 1B - 24 CL	0.50	0.70	50	1.4 ÷ 2.8
JCRm 1A - 24 CL	0.60	0.85	50	1.8 ÷ 3.2
JCRm 10H - 24 CL	0.75	1	50	2.0 ÷ 3.4
JCRm 15H - 24 CL	1.1	1.5	50	3.0 ÷ 4.0
JCRm 10M - 24 CL	0.75	1	80	1.4 ÷ 2.8
JCRm 15M - 24 CL	1.1	1.5	80	2.5 ÷ 4.0
<b>HYDROFRESH 60 CL</b>				
JSWm 10HX - 60 CL	0.75	1	50	2.0 ÷ 3.2
JSWm 12HX - 60 CL	0.90	1.25	50	2.5 ÷ 4.0
JSWm 15HX - 60 CL	1.1	1.5	50	3.0 ÷ 4.5
JSWm 10MX - 60 CL	0.75	1	80	1.4 ÷ 2.8
JSWm 12MX - 60 CL	0.90	1.25	80	2.0 ÷ 3.5
JSWm 15MX - 60 CL	1.1	1.5	80	2.5 ÷ 4.0

## COMPONENTS:

- Single-phase pump
- Tank
- Pressure switch
- Pressure gauge
- Hose (for 24CL and 60CL)
- Brass connector
- 1.5 m power cable with Schuko plug

(1) Maximum flow rate at the minimum recommended pressure switch pressure

(2) Recommended pressure range

## DIMENSIONS AND WEIGHT

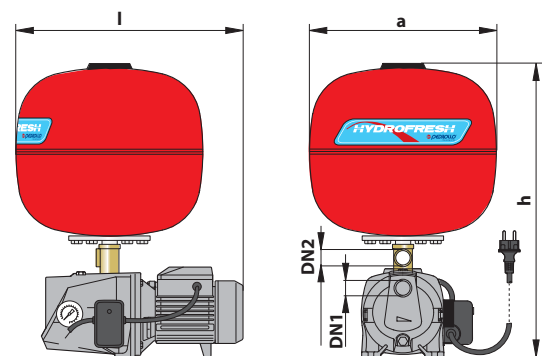

MODEL	PORTS		DIMENSIONS mm			WEIGHT kg
	DN1	DN2	l	a	h	
PKm 60 - 24 SF	1"	1"	383	360	568	12.6
JSWm 1CX - 24 SF	1"	1"	437	360	551	16.5
JSWm 1BX - 24 SF	1"	1"	437	360	551	17.3
JSWm 1AX - 24 SF	1"	1"	437	360	551	17.6
JSWm 10HX - 24 SF	1"	1"	463	360	572	21.0
JSWm 12HX - 24 SF	1"	1"	463	360	572	22.0
JSWm 15HX - 24 SF	1"	1"	463	360	572	22.4

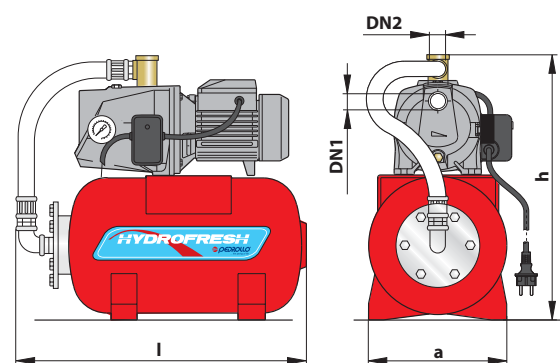

MODEL	PORTS		DIMENSIONS mm			WEIGHT kg
	DN1	DN2	l	a	h	
PKm 60 - 24 CL	1"	1"	540	255	503	13.2
PKm 65 - 24 CL	1"	1"	540	255	508	14.8
CPm 620 - 24 CL	1"	1"	540	255	585	19.9
CPm 650 - 24 CL	1¼"	1"	540	255	605	26.3
JSWm 1BX - 24 CL	1"	1"	540	265	486	17.9
JSWm 1AX - 24 CL	1"	1"	540	265	486	18.2
JSWm 10HX - 24 CL	1"	1"	540	315	507	21.6
JSWm 12HX - 24 CL	1"	1"	540	315	507	22.6
JSWm 15HX - 24 CL	1"	1"	540	315	507	23.0
JSWm 10MX - 24 CL	1"	1"	540	315	507	21.6
JSWm 12MX - 24 CL	1"	1"	540	315	507	22.6
JSWm 15MX - 24 CL	1"	1"	540	315	507	23.0
JCRm 1B - 24 CL	1"	1"	540	255	519	14.3
JCRm 1A - 24 CL	1"	1"	540	255	519	14.8
JCRm 10H - 24 CL	1¼"	1"	540	255	551	17.3
JCRm 15H - 24 CL	1¼"	1"	540	255	551	18.4
JCRm 10M - 24 CL	1¼"	1"	540	255	551	17.3
JCRm 15M - 24 CL	1¼"	1"	540	255	551	18.4

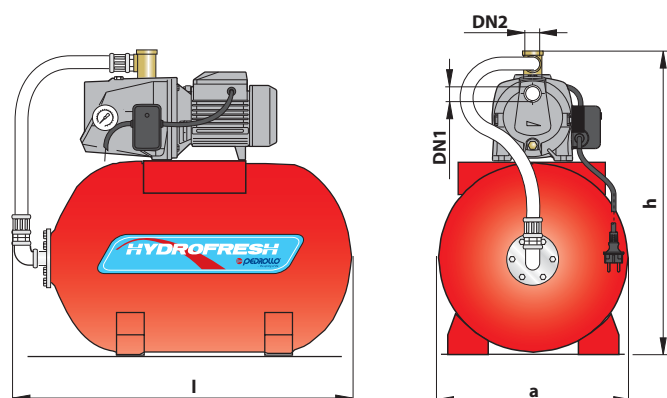

MODEL	PORTS		DIMENSIONS mm			WEIGHT kg
	DN1	DN2	l	a	h	
JSWm 10HX - 60 CL	1"	1"	750	380	647	28.2
JSWm 12HX - 60 CL	1"	1"	750	380	647	29.2
JSWm 15HX - 60 CL	1"	1"	750	380	647	29.6
JSWm 10MX - 60 CL	1"	1"	750	380	647	28.2
JSWm 12MX - 60 CL	1"	1"	750	380	647	29.2
JSWm 15MX - 60 CL	1"	1"	750	380	647	29.6